

Ranking of Refrigerants

GUILLERMO RESTREPO,^{*,†}
 MONIKA WECKERT,[†]
 RAINER BRÜGGEMANN,[§]
 SILKE GERSTMANN,[†] AND
 HARTMUT FRANK^{*,†}

Environmental Chemistry and Ecotoxicology, University of Bayreuth, Bayreuth, Germany, Leibniz-Institute of Freshwater Ecology and Inland Fisheries, Berlin, Germany, and Laboratorio de Química Teórica, Universidad de Pamplona, Pamplona, Colombia

Received October 17, 2007. Revised manuscript received December 19, 2007. Accepted January 2, 2008.

Environmental ranking of refrigerants is of need in many instances. The aim is to assess the relative environmental hazard posed by 40 refrigerants, including those used in the past, those presently used, and some proposed substitutes. Ranking is based upon ozone depletion potential, global warming potential, and atmospheric lifetime and is achieved by applying the Hasse diagram technique, a mathematical method that allows us to assess order relationships of chemicals. The refrigerants are divided into 13 classes, of which the chlorofluorocarbons, hydrofluorocarbons, hydrochlorofluorocarbons, hydrofluoroethers, and hydrocarbons contain the largest number of single substances. The dominance degree, a method for measuring order relationships among classes, is discussed and applied to the 13 refrigerant classes. The results show that some hydrofluoroethers are as problematic as the hydrofluorocarbons. Hydrocarbons and ammonia are the least problematic refrigerants with respect to the three environmental properties.

Introduction

Over the decades, various chemicals have been used as refrigerants; the selection of replacement substances has been motivated to avoid the disadvantages of the previous ones (1). Currently, the adverse environmental properties of the chlorofluorocarbons (CFCs) have led to regulation of their production and consumption (2–4) and, to some degree, also of the second generation alternatives, the hydrochlorofluorocarbons (HCFCs) and the hydrofluorocarbons (HFCs). Thus, further research is needed to find environmentally acceptable alternatives (5). In 2002 the global consumption of CFCs, HCFCs, and HFCs were 169, 496, and 209 kt y⁻¹, respectively.

The main drawback of CFCs and HCFCs is their depletion potential of the stratospheric ozone layer (7); together with the HFCs, they also contribute to global warming (4). Indicators for quantitative comparison of the various substances are ODP (8) (ozone depletion potential) and GWP (9) (global warming potential), which are closely related to their atmospheric lifetime (ALT) (10).

From an environmental point of view, an optimum refrigerant must have low ODP, GWP, and ALT values. The selection of suitable alternatives is not straightforward because there is no chemical embracing all lowest indicators at the same time. Therefore, appropriate substances must be selected by simultaneously and independently comparing and ranking them according to these environmental indicators. This can be achieved by partial order theory, as shown below.

Materials and Methods

Ranking. In a ranking procedure, different descriptors q_1, q_2, \dots, q_i are used to rank objects a, b, \dots that are gathered in a set G . For example, a set of chemicals $G = \{a, b, c, d, e, f, g\}$ may be described as shown in the data matrix depicted in Figure 1. A linear ranking is obtained if only one property q_1 is considered; for instance, linear ranking A is achieved if q_1 is regarded, and B results for q_2 (Figure 1). Because the descriptor q_2 of a is equal to that of b [$q_2(a) = q_2(b)$] and the one of e is equal to that of g [$q_2(e) = q_2(g)$], each of these pairs is equivalent in the ranking B, that is, $a \sim b$ and $e \sim g$. If q_1 and q_2 are environmental properties whose values increase with the extent of adverse impact, ranking A shows that a is the “most hazardous” substance, whereas for ranking B it is d . In real cases, the objects to be ranked are described by several descriptors, which all have to be considered simultaneously. Many ranking methods (11) perform a weighted combination of descriptors to yield a new superdescriptor. For instance, the utility function (12) $\Gamma(x)$ is calculated for each object x , giving a weight g_i to each descriptor q_i according to eq 1.

$$\Gamma(x) = \sum g_i \times q_i(x) \quad (1)$$

If equal priorities are assigned to q_1 and q_2 , $\Gamma(x)$ values can be depicted in a linear order (Figure 1C). Although all descriptors are simultaneously used, the determination of weights is still subjective. A ranking method avoiding these drawbacks is the Hasse diagram technique, previously applied to assess the environmental relevance of organic and inorganic chemicals (13–15).

Hasse Diagram Technique (HDT). In the HDT (14, 15), two objects x and y , characterized by the descriptors $q_1(x), q_2(x), \dots, q_i(x)$ and $q_1(y), q_2(y), \dots, q_i(y)$, are compared in such a way that x is ranked higher than y ($x \geq y$) if all its descriptors are higher than those of y ($q_i(x) > q_i(y)$ for all i), or if at least one descriptor is higher for x while all others are equal ($q_j(x) > q_j(y)$ for some j , $q_i(x) = q_i(y)$ for all others). In this case, x and y are said to be comparable. If all descriptors of x and y are equal, both substances are equivalent (14). It further follows that if $x \geq y$ and $y \geq z$ then $x \geq z$. If one descriptor q_j fulfills $q_j(x) < q_j(y)$ while the others are opposite ($q_i(x) \geq q_i(y)$), x and y are incomparable and are not ordered with respect to each other (14). Two objects are in “cover-relation” if they are comparable and if no third one is in between. Such order relationships can be graphically presented as a Hasse diagram (HD), drawn and analyzed with the software WHASSE (16) (available from Rainer Brüggemann) (Figure 1D).

The richness of a HD lies in the lines connecting the objects. Objects with lines only in the downward direction have the highest ranks (maximal objects) (17), for example a and d in Figure 1D. Objects with lines only in the upward direction have lowest ranks and are called minimal objects (17) (b and g in Figure 1D). The absence of a line between two objects means that they are incomparable. If there is a

* Corresponding author e-mail: hartmut.frank@uni-bayreuth.de; phone: +49 + 09 21 55-23 73; fax: +49 +09 21 55-23 34.

† University of Bayreuth.

‡ Universidad de Pamplona.

§ Leibniz-Institute of Freshwater Ecology and Inland Fisheries.

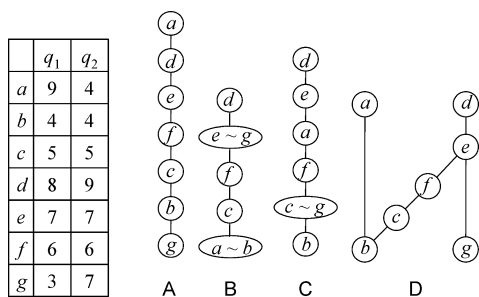

FIGURE 1. Data matrix of seven chemicals described by q_1 and q_2 ; rankings according to (A) q_1 and (B) q_2 ; (C) ranking due to a weighted combination of q_1 and q_2 (aggregation); (D) Hasse diagram.

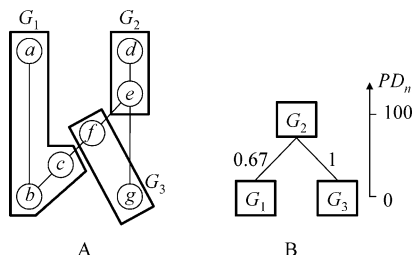

FIGURE 2. (A) Hasse diagram endowed with three classes. (B) Dominance diagram; the numbers next to the lines are dominance degree values, and the classes are oriented according to their percentage of dominated substances (PD_n).

sequence of lines connecting them in the same direction, for example, f and b , they are comparable ($f \geq b$), although no direct line is drawn between them because it is already contained in the path $f \geq c, c \geq b$ (16). According to the matrix (Figure 1), f and b are comparable because $q_1(b) < q_1(f)$ and $q_2(b) < q_2(f)$. Objects a and c are incomparable because $q_1(a) > q_1(c)$, but $q_2(a) < q_2(c)$. In a HD, such pairs are recognized because there are no lines between them, or they are connected by lines not following the same direction, for example, b and g in Figure 1D.

According to Figure 1D, a is more problematic than b . Any comparison of a with another chemical requires additional knowledge about the importance of the descriptors. For example, the ranking in Figure 1C entails the same relation between a and b , but also $a > f, a > c$ and $a > g$, caused by the weighted aggregation involved in this method (1). With the HD, however, it is possible to state that d is more problematic than all other compounds except a , whereas the utility function (Figure 1C) yields d as more problematic than all others including a . The presence of two maximal objects in the HD, a and d , shows how questionable a weighted aggregation of descriptors may be because subjective weights may lead to rankings with either a or d as most problematic.

Avoidance of such an aggregation prevents overestimation of statistically dependent descriptors due to subjectively determined aggregation weights.

The Dominance Degree. A set of substances G may contain several “classes” which can be found either by unsupervised classifications, such as cluster analysis, or in a supervised manner. The question is whether it is possible to rank such classes. This can be done with standard statistical techniques, for example, calculating medians or means and ranking based on them. Nevertheless, the order-theoretical approach of dominance degree (18) is preferable because it extends the parameter-free method of HDT. Two disjoint classes (subsets) G_n and G_m in G are formed, of which G_n completely dominates G_m if for all x in G_n and for all y in $G_m, y \leq x$. The condition “for all” implies that all objects in G_n are ranked higher than those in G_m . In practice, this is not

always the case because it often occurs that some objects of G_n and G_m are incomparable, or some objects in G_n may be ranked higher than those in G_m , while some others are lower. Hence, it is necessary to quantify how many objects in G_n are ranked higher than those in G_m ; this dominance of G_n over G_m is determined as dominance degree.

The dominance degree is defined as $\text{Dom}(G_n, G_m) = N_R / N_T$, where $N_R = |\{(x, y), x \in G_n, y \in G_m, \text{ and } y \leq x\}|$ and $N_T = |G_n| \times |G_m|$ ($|X|$: number of objects in a set X). Hence, $\text{Dom}(G_n, G_m)$ is the fraction of total theoretical order relationships (N_T) for which the objects of G_n are ranked higher than those in G_m . $\text{Dom}(G_n, G_m)$ may range from 0 to 1; 1 means that all objects in G_n are ranked higher than those in G_m (class G_n dominates class G_m), whereas for 0 no object in G_n is ranked higher than an object in G_m . In this work, values of $\text{Dom}(G_n, G_m) > 0.5$ have been used for expressing dominances, meaning that for more than half of the relations between the two classes a compound in G_n is ranked higher than one in G_m .

To demonstrate the application of the dominance degree concept, the set G (Figure 1) is divided into three classes, namely $G_1 = \{a, b, c\}, G_2 = \{d, e\}$ and $G_3 = \{f, g\}$ (Figure 2A). The dominance degree values are calculated as shown in eqs 2–7:

$$\text{Dom}(G_1, G_2) = \frac{\emptyset}{\{(a, d), (a, e), (b, d), (b, e), (c, d), (c, e)\}} = \frac{0}{6} = 0 \quad (2)$$

$$\text{Dom}(G_1, G_3) = \frac{\emptyset}{\{(a, f), (a, g), (b, f), (b, g), (c, f), (c, g)\}} = \frac{0}{6} = 0 \quad (3)$$

$$\text{Dom}(G_2, G_1) = \frac{\{(d, b), (d, c), (e, b), (e, c)\}}{\{(d, a), (d, b), (d, c), (e, a), (e, b), (e, c)\}} = \frac{4}{6} = 0.67 \quad (4)$$

$$\text{Dom}(G_2, G_3) = \frac{\{(d, f), (d, g), (e, f), (e, g)\}}{\{(d, f), (d, g), (e, f), (e, g)\}} = \frac{4}{4} = 1 \quad (5)$$

$$\text{Dom}(G_3, G_1) = \frac{\{(f, b), (f, c)\}}{\{(f, a), (f, b), (f, c), (g, a), (g, b), (g, c)\}} = \frac{2}{6} = 0.33 \quad (6)$$

$$\text{Dom}(G_3, G_2) = \frac{\emptyset}{\{(f, d), (f, e), (g, d), (g, e)\}} = \frac{0}{4} = 0 \quad (7)$$

Obviously, G_1 and G_3 do not dominate any class because their values are lower than 0.5, but G_2 dominates G_1 and G_3 . Dominance relationships are presented in the dominance diagram (Figure 2B) where a line is drawn between classes only when $\text{Dom}(G_n, G_m) > 0.5$; as a convention G_n is located higher than G_m . The value $\text{Dom}(G_2, G_1) = 0.67$ shows that 67% of the objects in G_2 are more problematic than those in G_1 , and $\text{Dom}(G_2, G_3) = 1$ that all in G_2 are more problematic than those in G_3 . The percentage of objects dominated by G_n (PD_n) can be calculated by adding the number of objects in all classes G_i dominated by G_n and then dividing the result by the number of objects that might be dominated, that is, $|G| - |G_n|$:

$$PD_n = \frac{\sum |G_i|}{|G| - |G_n|} \quad (8)$$

Classes of Refrigerants and Their Properties. In this work, a set G comprising 40 refrigerants (Table 1; Figure S.1 of the Supporting Information) is divided into 13 classes: CFC, HFC, HCFC, hydrocarbons (HC), di(fluoroalkyl)ethers (DFAE), alkylfluoroalkylethers (AFAE), chloromethanes (CM), and the single-compound classes trifluoriodomethane (FIM), octafluorocyclobutane (PFC), carbon dioxide (CO_2), bromochlorodifluoromethane (BCF), dimethyl ether (DME), and ammonia (NH_3).

TABLE 1. Refrigerants Included in This Study, Their Labels, Chemical Classes, Molecular Formulas, Chemical and Nonproprietary Names, and Their ODP, GWP, and ALT Values

label	class	molecular formula	chemical name	nonproprietary name	ODP [relative to R11]	GWP relative to CO ₂ [100 y time horizon]	ALT [y]
1	CFC	CCl ₃ F	trichloro-fluoromethane	R11	1 ^a	4680 ^a	45 ^a
2	CFC	CCl ₂ F ₂	dichloro-difluoromethane	R12	0.82 ^a	10720 ^a	100 ^a
3	HCFC	CHClF ₂	chlorodifluoro-methane	R22	0.05 ^a	1780 ^a	12 ^a
4	HCFC	C ₂ HCl ₂ F ₃	2,2-dichloro-1,1,1-trifluoroethane	R123	0.022 ^a	76 ^a	1.3 ^a
5	HCFC	C ₂ HClF ₄	2-chloro-1,1,1,2-tetrafluoroethane	R124	0.022 ^b	599 ^a	5.8 ^a
6	HCFC	C ₂ H ₃ Cl ₂ F	1,1-dichloro-1-fluoroethane	R141b	0.12 ^a	713 ^a	9.3 ^a
7	HCFC	C ₂ H ₃ ClF ₂	1-chloro-1,1-difluoroethane	R142b	0.065 ^a	2270 ^a	17.9 ^a
8	HFC	CHF ₃	trifluoromethane	R23	0.0004 ^b	14310 ^a	270 ^a
9	HFC	CH ₂ F ₂	difluoromethane	R32	0 ^c	670 ^a	4.9 ^a
10	HFC	C ₂ HF ₅	pentafluoroethane	R125	0.00003 ^b	3450 ^a	29 ^a
11	HFC	C ₂ H ₂ F ₄	1,1,1,2-tetrafluoroethane	R134a	0.000015 ^c	1410 ^a	14 ^a
12	HFC	C ₂ H ₃ F ₃	1,1,1-trifluoroethane	R143a	0 ^c	4400 ^a	52 ^a
13	HFC	C ₂ H ₄ F ₂	1,1-difluoroethane	R152a	0 ^d	122 ^a	1.4 ^a
14	HFC	C ₃ H ₃ F ₅	1,1,1,3,3-pentafluoropropane	R245fa	0 ^f	950 ^e	7.2 ^e
15	HFC	C ₃ H ₂ F ₆	1,1,1,3,3,3-hexafluoropropane	R236fa	0 ^f	9400 ^e	220 ^e
16	HC	C ₃ H ₈	<i>n</i> -propane	R290	0 ^c	20 ^c	0.041 ^a
17	HC	C ₄ H ₁₀	<i>n</i> -butane	R600	0 ^c	20 ^c	0.018 ^a
18	HC	C ₄ H ₁₀	isobutane	R600a	0 ^d	20 ^d	0.019 ^a
19	HC	C ₅ H ₁₂	<i>n</i> -pentane	R601	0 ^g	0 ^h	0.01 ^a
20	HC	C ₃ H ₆	propene	R1270	0 ^c	3 ⁱ	0.001 ^a
21	CO ₂	CO ₂	carbon dioxide	R744	0 ^d	1 ^b	120 ^j
22	BCF	CBrClF ₂	bromochloro-difluoromethane	R12B1	5.1 ^a	1300 ^e	11 ^e
23	PFC	C ₄ F ₈	octafluorocyclobutane	RC318	0 ^f	10000 ^f	3200 ^f
24	HFC	C ₃ HF ₇	1,1,1,2,3,3,3-heptafluoropropane	R227ea	0 ^f	3500 ^e	33 ^e
25	AFAE	C ₄ H ₃ F ₇ O	heptafluoropropyl methyl ether	HFE-7000	0 ^a	450 ^k	4.7 ^k
26	AFAE	C ₅ H ₃ F ₉ O	methyl nonafluorobutyl ether	HFE-7100	0 ^a	410 ^k	5 ^k
27	AFAE	C ₆ H ₅ F ₉ O	ethyl nonafluorobutyl ether	HFE-7200/ HFE-569mccc	0 ^a	60 ^k	0.77 ^k
28	AFAE	C ₉ H ₅ F ₁₅ O	ethyl pentadecafluoroheptyl ether	HFE-7500	0 ^a	100 ^k	2.2 ^k
29	DFAE	C ₂ HF ₅ O	pentafluorodimethyl ether	HFE-125	0 ^a	14800 ^k	165 ^k
30	DFAE	C ₂ H ₂ F ₄ O	1,1,1',1'-tetrafluorodimethyl ether	HFE-134	0 ^a	5760 ^k	27.25 ^k
31	CM	CH ₂ Cl ₂	methylene chloride	R30	0 ^f	10 ^a	0.38 ^a
32	CM	CH ₃ Cl	methyl chloride	R40	0.02 ^a	16 ^a	1.3 ^a
33	CFC	C ₂ Cl ₃ F ₃	1,1,2-trichloro-1,2,2-trifluoroethane	R113	0.9 ^a	6000 ^f	85 ^a
34	HCFC	CHCl ₂ F	dichlorofluoromethane	R21	0.01 ^f	210 ^e	2 ^e
35	CFC	C ₂ Cl ₂ F ₄	1,2-dichloro-1,1,2,2-tetrafluoroethane	R114	0.85 ^f	9800 ^e	300 ^a
36	FIM	CF ₃ I	trifluoroiodomethane	R1311	0 ^f	1 ^e	0.1 ^f
37	DME	C ₂ H ₆ O	dimethyl ether		0 ^f	1 ^a	0.015 ^a
38	NH ₃	NH ₃	ammonia	R717	0 ^c	0 ⁱ	0.25 ^a
39	AFAE	C ₂ H ₃ F ₃ O	methyl trifluoromethyl ether	HFE-143	0 ^a	656 ^k	5.7 ^k
40	AFAE	C ₃ H ₃ F ₅ O	methyl pentafluoroethylether	HFE-245	0 ^a	697 ^k	4 ^k

^a Reference (6). ^b Reference (22). ^c Reference (23). ^d Reference (24). ^e Reference (9). ^f Reference (25). ^g Reference (26). ^h Reference (27). ⁱ Reference (28). ^j Reference (29). ^k Reference (30).

ODP was originally defined (8) to represent the amount of ozone destroyed relative to the amount of compound emitted. The numerical value is obtained by integrating over its entire atmospheric lifetime. Because ODP is related to ALT (10), only chlorinated or brominated substances with ALT values of several years may reach the stratosphere to react with ozone. Trichlorofluoromethane (R11) is used as reference for the ODP calculation. Thus, ODP particularly applies to substances with similar reactivity. The fact that the relative concentration of a compound changes with time has led to the definition of specific time horizons for ODP calculations (19).

GWP (9) is an index determining the greenhouse efficiency of a gas relative to carbon dioxide. GWP is related to ALT because a chemical with high infrared absorption holds high GWP if ALT is high. Considerations on the appropriateness of carbon dioxide as reference have led to propose the halocarbon global warming potential with R11 as reference (20).

Because of the comparative aim of the present paper, the refrigerants studied must be described by indices with common reference substances. Therefore, the chemicals studied here are characterized by their ODP relative to R11,

and their ALT. These values are taken from the literature (Table 1). In the following, the application of the HDT to the refrigerants is discussed, as well as the dominance relationships among the 13 classes.

Because basic HDT does not involve any aggregating function (METEOR (21) does it) to combine descriptors but considers them simultaneously and independently, the fact that ODP and GWP are related to ALT does not entail an overestimation of the latter.

Results and Discussion

The Simpson diversity index *D* (31) has been calculated (Supporting Information S3) to determine the diversity of the set consisting of 13 classes. The obtained value, *D* = 0.89, shows that the set is large-diverse, which ensures that one class relative to the others is not overpopulated. The HD of the 13 classes is shown in Figure 3; substances at the top of the diagram are most problematic, those at the bottom least.

Eight maximal refrigerants with high impact, regarding ALT, ODP, and GWP, and two minimal ones are shown. The maximal ones belong to classes DFAE, CFC, BCF, HFC, and PFC, and the minimal ones belong to the class HC. Not all

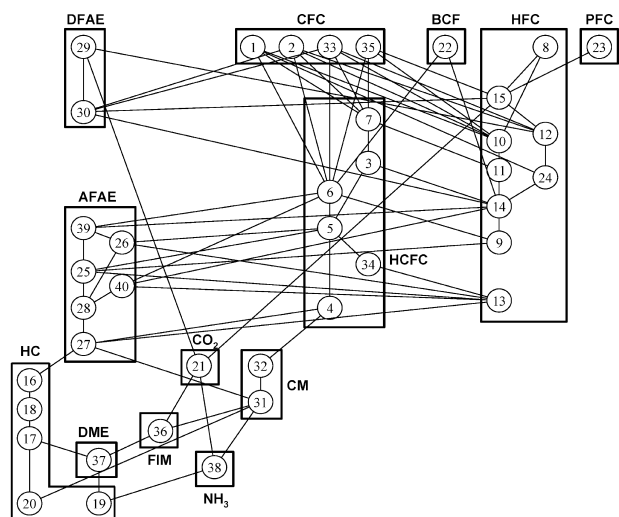

FIGURE 3. Hasse diagram of 40 refrigerants and its 13 classes, shown as boxes.

members of the high classes are maximal substances; for example, of the DFAE 1,1,1',1'-tetrafluoro-dimethyl ether, (30), is not a maximal refrigerant as 29. Similarly, for HFC the only maximal substance is 8; of the CFCs, all are maximal chemicals. Similarly, in the low class HC, *n*-pentane (19) and propene (20) are minimal substances, but the other members are not.

Dominance degrees among the 13 classes are calculated, appearing in Table 2 as a square matrix. The dominance values correspond to $\text{Dom}(G_n, G_m)$ where G_n is always a class labeling a column and G_m is a class labeling a row. The matrix is not symmetrical because of the order properties on which it is based; therefore, $\text{Dom}(G_n, G_m)$ can be different to $\text{Dom}(G_m, G_n)$.

Potentially, there are 156 dominance relationships among the 13 classes ($13 \times 13 = 169$, minus 13 diagonal elements), one-third of which corresponding to $\text{Dom}(G_n, G_m) > 0.5$, and two-thirds to $\text{Dom}(G_n, G_m) \leq 0.5$. There are 27.6% total dominances ($\text{Dom}(G_n, G_m) = 1$) and 55.8% nondominances ($\text{Dom}(G_n, G_m) = 0$). The corresponding dominance diagram is shown in Figure 4.

Depending on the particular order relationships among the considered classes, a dominance diagram may or may not fulfill the transitivity axiom, that is, if class *A* dominates class *B*, and *B* dominates class *C*, then *A* dominates *C* (32). If the axiom is met, the dominance of *A* over *C* is graphically represented by the dominance of *A* over *B* and of *B* over *C*. In the present case, the transitivity axiom is fulfilled.

CFC is the class that dominates most other substances. Each of the classes CFC, PFC, and BCF dominates more than half of the refrigerants with respect to ODP, GWP, and ALT. The second generation alternatives, HCFC and HFC, dominate less than half of the other substances, which means that they are environmentally less problematic than CFC, PFC, and BCF. Although problematic HCFCs will be replaced by HFC-blends in refrigeration equipment before 2010 (33), it is noteworthy that the class HCFC does not dominate the class HFC; the environmental suitability of the latter as replacements is, thus, questionable. Particularly, three HFC-blends, namely, R410A, R407C, and R404A, will replace chlorodifluoromethane (3 in Table 1 and Figure 3). R410 is a blend of difluoromethane (9) and pentafluoroethane (10); R407C is a blend of 9, 10, and 1,1,1,2-tetrafluoroethane (11); and R404A is a blend of 10, 11, and 1,1,1-trifluoroethane (12). Only 9 is ranked lower than 3, whereas the other HFCs are incomparable with 3 (Figure 3).

The classes DFAE and AFAE, both hydrofluoroethers, appear at lower PD_n values (Figure 4). Class DFAE dominates

37% of all the other chemicals, a value close to the one of HFC (45%) on the PD_n axis. None of the classes dominates DFAE, not even CFC, which accounts for the largest percentage of domination. Therefore, it is not possible to state that chemicals belonging to DFAE are less problematic than CFC, PFC, or BCF, although they were introduced as CFC replacements. AFAE, the other group of hydrofluoroethers, is dominated by all other problematic refrigerants, including the class DFAE. This is possibly caused by the particular distribution of fluorine atoms along the molecules; DFAE compounds have fluorine substituents on both alkyl groups, whereas AFAE compounds have fluorine only on one. Hence, further studies in this direction should be carried out; some preliminary investigations on structure–property relationships regarding their tropospheric lifetimes have been done (34, 35).

There are six classes with PD_n values (Figure 4) lower than 8%, that is, CM, CO_2 , HC, FIM, DME, and NH_3 , representing the environmentally most acceptable refrigerants. It is particularly important to note that CFC, HCFC, HFC, DFAE, and AFAE dominate HC and NH_3 , two substance classes that, earlier, were considered as problematic and that have motivated the development of CFC in the 1930s (36). Therefore, when comparing HC and NH_3 with their replacements on the basis of the three descriptors, ODP, GWP, and ALT, the former are better. Nevertheless, for a more general ranking, other aspects important for practical applications must be considered, such as energy efficiency, toxicity, and flammability. Qualitatively, it can be foreseen that DME and HC are problematic with respect to flammability, that carbon dioxide and HC are the least recommendable with respect to energy efficiency, and that particular attention must be paid to the toxicity of ammonia. The simultaneous analysis of these additional descriptors by applying HDT will result in a nonsubjective ranking to find the least problematic compounds.

Information on the relative order among classes is based on the ranking of chemicals, which in turn depends on the numerical values of the properties selected for their description. Small variations of the values may potentially affect the order relationships. To study this effect, each of the three environmental properties, continuous in concept, was classified, and the effect on the dominance degree values was studied. The three properties were transformed into 37 scores (Tables S.1–S.3, Supporting Information) by dividing each property into 37 equidistant intervals. Differences between the original dominance degree values and those obtained after classification were calculated (Tables S.4 and S.5, Supporting Information); the average variation of these differences was 0.11, indicating that the effect of classification on the dominance relationships is about 11%, that is, 89% of the dominance relationships are invariant toward property classification. Thus, dominance relationships found in this research are robust (15) with respect to numerical noise.

The main aim of this manuscript was to explore the order relationships among classes of chemicals; there are some other studies (14) that can be done based on HD, such as (a) stability analysis (37) of the diagram under addition or deletion of properties, (b) study of the most influential properties on the structure of the diagram (sensitivity analysis 14, 38), (c) application of dimension analysis (17) to know if the same diagram can be obtained combining some nonredundant properties, and (d) step-by-step weighted aggregation of descriptors to obtain a linear ranking. Results on the application of the latter study are found in ref 39.

The method described can be applied to any number of substances, although they are illustrated here with a limited number. In fact, a HD compares objects' descriptor values without regarding the number of objects. Therefore, such

TABLE 2. Dominance Matrix of the 13 Classes of Refrigerants

	CFC	HFC	PFC	DFAE	AFAE	HCFC	CM	FIM	HC	CO ₂	BCF	DME	NH ₃
CFC	ND ^a	0	0	0	0	0	0	0	0	0	0	0	0
HFC	0.78	ND	0.63	0.44	0.07	0.2	0	0	0	0	0.33	0	0
PFC	0	0	ND	0	0	0	0	0	0	0	0	0	0
DFAE	0.38	0.11	0.5	ND	0	0	0	0	0	0	0	0	0
AFAE	1	0.85	1	1	ND	0.73	0	0	0	0	1	0	0
HCFC	1	0	0	0	0	ND	0	0	0	0	0.67	0	0
CM	1	0.5	0.5	0.5	0.5	0.92	ND	0	0	0	1	0	0
FIM	1	1	1	1	1	1	1	ND	0	1	1	0	0
HC	1	1	1	1	1	1	0.4	0.2	ND	0.2	1	0.2	0.2
CO ₂	0.25	0.22	1	0.5	0	0	0	0	0	ND	0	0	0
BCF	0	0	0	0	0	0	0	0	0	0	ND	0	0
DME	1	1	1	1	1	1	1	1	0.6	1	1	ND	0
NH ₃	1	1	1	1	1	1	1	0	0	1	1	0	ND

^a The dominance degree for diagonal elements is not defined (ND).

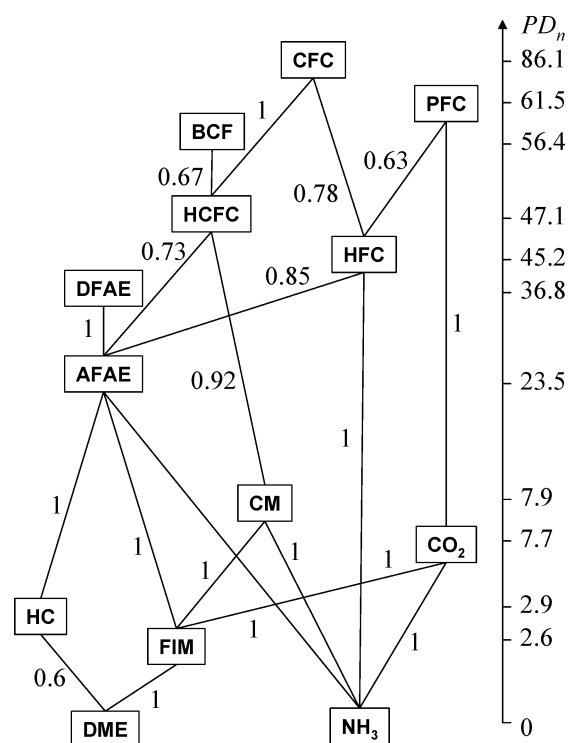

FIGURE 4. Dominance diagram for the 13 refrigerant classes ($Dom(G_n, G_m) > 0.5$); the numbers next to the lines are the dominance degree values, and the classes are oriented according to their PD_n (8).

dominance degree calculations are not restricted by the size of classes or by the number of compounds.

Acknowledgments

The authors thank the Bavarian Environmental Agency for supporting this study under the Research Project 81-00213381. G. Restrepo specially thanks COLCIENCIAS and the Universidad de Pamplona for the grant offered during the development of this research.

Abbreviations

AFAEs	alkylfluoroalkyl ethers
ALT	atmospheric lifetime
BCF	bromochlorodifluoromethane
CFCs	chlorofluorocarbons
CMs	chloromethanes
DFAEs	di(fluoroalkyl) ethers
DME	dimethyl ether

Dom	dominance degree
FIM	trifluoriodomethane
GWP	global warming potential
HCs	hydrocarbons
HCFCs	hydrochlorofluorocarbons
HD	Hasse diagram
HDT	Hasse diagram technique
HFCs	hydrofluorocarbons
HFEs	hydrofluoro ethers
ODP	ozone depletion potential
PD_n	percentage of classes dominated
PFC	octafluorocyclobutane (a perfluorocarbon)

Supporting Information Available

Molecular structures of the refrigerants analyzed, explanation of the Simpson diversity index and its calculation for the 13 classes of refrigerants, tables for the equidistant classification of refrigerant properties and for the analysis of its effect on the dominance degree values. This material is available free of charge via the Internet at <http://pubs.acs.org>.

Literature Cited

- (1) Calm, J. M.; Didion, D. A. Trade-Offs in Refrigerant Selections: Past, Present and Future. In *Proceedings of the ASHRAE/NIST Refrigerants Conference, Gaithersburg, Maryland, October 6–7, 1997*; American Society of Heating, Refrigerating, and Air-Conditioning Engineers: Atlanta, GA, 1997; republished in *Int. J. Refrig.* **1998**, *21*, 308–321.
- (2) *Montreal Protocol on Substances that Deplete the Ozone Layer*; United Nations Environment Programme: Nairobi, Kenya, 1987.
- (3) *Montreal Protocol on Substance that Deplete the Ozone Layer*; United Nations Environment Programme: Montreal, Canada, 1998.
- (4) *Kyoto Protocol to the United Nations Framework Convention on Climate Change, United Nations Framework Convention on Climate Change*, United Nations: Geneva, 1997.
- (5) Bovea, M. D.; Cabello, R.; Querol, D. Comparative life cycle assessment of commonly used refrigerants in commercial refrigerants systems. *Int. J. Life Cycle Ass.* **2007**, *12*, 299–307.
- (6) Intergovernmental Panel on Climate Change/Technology and Economic Assessment Panel. *Special Report on Safeguarding the Ozone Layer and the Global Climate System; Issues Related to Hydrofluorocarbons and Perfluorocarbons*; Cambridge University Press: Cambridge, 2006.
- (7) Molina, M. J.; Rowland, F. S. Stratospheric sink for chlorofluoromethanes: Chlorine atom-catalysed destruction of ozone. *Nature* **1974**, *249*, 810–812.
- (8) Wuebbles, D. J. Chlorocarbon emission scenarios — Potential impact on stratospheric ozone. *J. Geophys. Res.* **1983**, *88*, 1433–1443.
- (9) *Climate Change 2001: The Scientific Basis; Contribution of Working Group I to the Third Assessment Report of the Intergovernmental Panel on Climate Change*; Cambridge University Press: New York, 2001.

- (10) Kurylo, M. J.; Orkin, V. L. Determination of atmospheric lifetimes via the measurement of OH radical kinetics. *Chem. Rev.* **2003**, *103*, 5049–5076.
- (11) Davis, G. A.; Swanson, M.; Jones, S. Comparative Evaluation of Chemical Ranking and Scoring Methodologies, EPA Order No. 3N-3545-NAEX; United States Environmental Protection Agency: Washington DC, 1994.
- (12) Seip, K. L. Restoring water quality in the metal polluted Soerfjorden, Norway. *Ocean Coast. Manage.* **1994**, *22*, 19–43.
- (13) Lerche, D.; Brüggemann, R.; Sørensen, P.; Carlsen, L.; Nielsen, O. J. A comparison of partial order technique with three methods of multi-criteria analysis for ranking of chemical substances. *J. Chem. Inf. Comput. Sci.* **2002**, *42*, 1086–1098.
- (14) Brüggemann, R.; Bartel, H. G. A theoretical concept to rank environmentally significant chemicals. *J. Chem. Inf. Comput. Sci.* **1999**, *39*, 211–217.
- (15) Brüggemann, R.; Münzer, B. A graph-theoretical tool for priority setting of chemicals. *Chemosphere* **1993**, *27*, 1729–1736.
- (16) Brüggemann, R.; Halfon, E.; Bücherl, C. *Theoretical Base of the Program "Hasse"*; GSF-Bericht 20/95: Neuherberg, 1995.
- (17) Trotter, W. T. *Combinatorics and Partially Ordered Sets, Dimension Theory*; The Johns Hopkins University Press: Baltimore, 1992.
- (18) Restrepo, G.; Brüggemann, R.; Voigt, K. Partially ordered sets in the analysis of alkanes fate in rivers. *Croat. Chem. Acta* **2007**, *80*, 261–270.
- (19) Solomon, S.; Albritton, D. L. Time-dependent ozone depletion potentials for short- and long-term forecasts. *Nature* **1992**, *357*, 33–37.
- (20) Fisher, D. A.; Hales, C. H.; Wang, W.-C.; Ko, M. K. W.; Sze, N. D. Model calculations of the relative effects of CFCs and their replacements on global warming. *Nature* **1990**, *344*, 513–516.
- (21) Simon, U.; Brüggemann, R.; Behrendt, H.; Shulenberger, E.; Pudenz, S. METEOR: A step-by-step procedure to explore effects of indicator aggregation in multi criteria decision aiding — Application to water management in Berlin, Germany. *Acta hydrochim. Hydrobiol.* **2006**, *34*, 126–136.
- (22) Scientific Assessment of Ozone Depletion: 2002; *Global Ozone Research and Monitoring Project - Report No. 47*; World Meteorological Organization, Geneva, Switzerland, 2003.
- (23) Forschungszentrum für Kältetechnik und Wärmepumpen GmbH *Ersatz des Kältemittels R22 in bestehenden Kälte- und Klimaanlage - Aktueller Stand — Studie im Auftrag des Umweltbundesamtes, Hannover*, Auftrag des Umweltbundesamtes: Hannover, 2000.
- (24) Devotta, S.; Padalkar, A. S.; Sane, N. K. Performance assessment of HC-290 as a drop-in substitute to HCFC-22 in a window air conditioner. *Int. J. Refrig.* **2005**, *28*, 594–604.
- (25) Calm, J. M.; Hourahan, G. C. Refrigerant data summary. *Eng. Syst.* **2001**, *18*, 74–88.
- (26) von Cube, H. L.; Steinle, F.; Lotz, H.; Kunis, J. *Lehrbuchder, Kältetechnik, Band 1, 4. Auflage*; C. F. Müller Verlag: Heidelberg, 1997.
- (27) Galvin, J. B.; Marashi, F. *n*-Pentane. *J. Toxicol. Env. Heal. A* **1999**, *58*, 35–56.
- (28) *Kältemittelreport 13. Auflage A-500-13*; Bitzer International: Sindelfingen, Germany, 2004; <http://www.bitzer.de>.
- (29) Nieto de Castro, C. A.; Mardolcar, U. V.; Matos Lopes, M. L. Thermophysical properties of environmentally acceptable refrigerants. In *Stratospheric Ozone Depletion/ UV-B Radiation in the Biosphere*; Biggs, R. H.; Joyner, M. E. B., Eds.; Springer: Berlin, 1994; pp 27–34, Vol. 18.
- (30) Tsai, W. T. Environmental risk assessment of hydrofluoroethers (HFEs). *J. Hazard. Material.* **2005**, *119*, 69–78.
- (31) Villanueva, L.; Navarrete, A.; Urmeneta, J.; White, D. C.; Guerrero, R. Analysis of diurnal and vertical microbial diversity of a hypersaline microbial mat. *Arch. Microbiol.* **2007**, *188*, 137–146.
- (32) Restrepo, G.; Brüggemann, R. Dominance and separability in posets, their application to isoelectronic species with equal total nuclear charge. *J. Math. Chem.* **2007**, DOI: 10.1007/s10910-007-9331-x.
- (33) Tullo, A. H. The switch is on for refrigerants. *Chem. Eng. News* **2006**, *84*, 24–25.
- (34) Cooper, D. L.; Cunningham, T. P.; Allan, N. L.; McCulloch, A. Potential CFC replacements: Tropospheric lifetimes of C₃ hydrofluorocarbons and hydrofluoroethers. *Atmos. Environ. A* **1993**, *27*, 117–119.
- (35) Güsten, H.; Medven, Ž.; Sekušak, S.; Sabljic, A. Predicting tropospheric degradation of chemicals: From estimation to computation. *SAR & QSAR Environ. Res.* **1995**, *4*, 197–209.
- (36) Powell, R. L. CFC phase-out: Have we met the challenge. *J. Fluorine Chem.* **2002**, *114*, 237–250.
- (37) Brüggemann, R.; Voigt, K. Stability of comparative evaluation, -example: Environmental databases. *Chemosphere* **1996**, *33*, 1997–2006.
- (38) Brüggemann, R.; Münzer, B.; Halfon, E. An algebraic/graphical tool to compare ecosystems with respect to their pollution — The German River "Elbe" as an example — I: Hasse-diagrams. *Chemosphere* **1994**, *28*, 863–872.
- (39) Restrepo, G.; Brüggemann, R.; Weckert, M.; Gerstmann, S.; Frank, H. Ranking patterns, An application to refrigerants. *MATCH Commun. Math. Comput. Chem.* **2008**, *59*, 555–584.

ES7026289